

THIS DRAWING HAS BEEN GENERATED BY A CAD SYSTEM. CHANGES SHALL ONLY BE INCORPORATED AS DIRECTED BY THE DESIGN ACTIVITY. DO NOT REVISE MANUALLY.

REVISIONS			
REV.	DESCRIPTION	ECO	DATE
B	ADD ISOVIEW	20-003	03/30/20
			APPROVED P.T

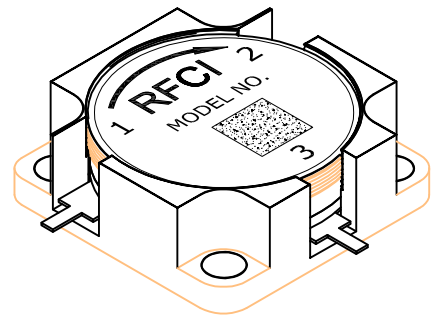
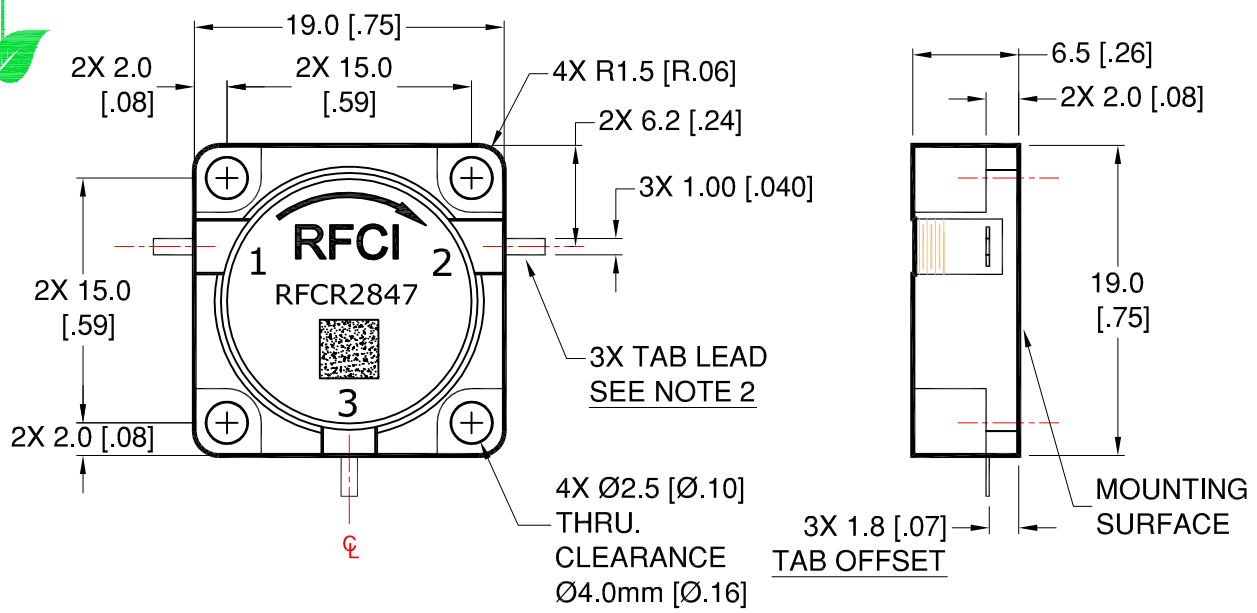

Finish:
 Body Housing: Steel, Nickel plated
 Tab Lead: Be-Cu, Silver plated

Terminal:
 Port (1)-(2): Input-Output
 Port (2)-(3): Input-Output
 Port (3)-(1): Input-Output

Specifications

Parameter	Minimum	Typical	Maximum
Frequency Range (MHz)	2200		2300
Insertion Loss: In-Out (dB)		< 0.20	0.30
Isolation: Out-In (dB)	22	> 25	
Return Loss: All Ports (dB)	22	> 25	
FWD IMD: 2T at ___W per T 5MHz Spacing (dBc)		tbd	

Permanent damage to the Device or reduce reliability If exceeding any of the limits.
 Port (1),(2)and (3): DC connected and floating as the only ground connection.

Power & Temperature Ratings

Parameter	Maximum
Forward PWR Peak/CW	1000/100 Watts
Reverse PWR Peak/CW	1000/100 Watts
Operating Temperature	-40 to +85° C
Storage Temperature	-40 to +95° C

- Notes:
 1. Typical Values Represent Performance @ +23 °C
 2. Tab Dimensions: 1.00 [.040]W x 2.5 [.10]L x 0.20 [.008]T
 3. S-Parameters to be measured by connecting Port 1 and 2 to VNA, and Port 3 to Load with return loss 30dB or higher
 4. MATRIX BARCODE: PART No., SN, DATE CODE

CW CIRCULATOR MODEL: RFCR2847

UNLESS OTHERWISE SPECIFIED ALL DIMENSIONS ARE IN MILLIMETERS [INCHES]: TOLERANCES ARE: 1 PLACE DECIMAL ±.2 [±.01] ANGULAR: ±1.0° 2 PLACE DECIMAL ±.10 [±.004] SURFACE ROUGHNESS 16/	THIRD ANGLE PROJECTION 	
	APPROVALS _____ DATE _____ DRAWN BY: _____ CHECKED BY: _____ DESIGN BY: _____ ENGINEER BY: _____ MFG. ENGR. _____ Q.A. _____ PROG. MGMT/MKT _____	
REMOVE ALL BURRS AND BREAK SHARP EDGES. SURFACE TEXTURE TO BE IN ACCORDANCE WITH LATEST ANSI B46.1 DIMENSIONING & TOLERANCING IN ACCORDANCE WITH LATEST ANSI Y14.5 PROPRIETARY NOTE: "THE INFORMATION CONTAINED ON THIS DOCUMENT IS CONSIDERED TO BE CONFIDENTIAL MATERIAL PROPRIETARY TO RF CIRCULATOR ISOLATOR Inc. (RFCI) AND IS PROVIDED SOLELY FOR INFORMATION PURPOSES. THIS INFORMATION SHALL NOT BE USED BY ANYONE OTHER THAN RFCI TO DESIGN OR CONSTRUCT ANY OF THE ITEMS DEPICTED, NOR SHALL IT BE DISCLOSED, DUPLICATED, OR COPIED FOR ANY PURPOSE, NOR MADE AVAILABLE TO ANY THIRD PARTY WITHOUT THE PRIOR WRITTEN CONSENT OF A RFCI OFFICIAL."	SIZE A CAGE NO. _____ DWG NO. CR2847-OS REV. B	
DO NOT SCALE DRAWING	SCALE: FULL	SHEET 1 OF 1