

THIS DRAWING HAS BEEN GENERATED BY A CAD SYSTEM. CHANGES SHALL ONLY BE INCORPORATED AS DIRECTED BY THE DESIGN ACTIVITY. DO NOT REVISE MANUALLY.

| REVISIONS |                 |      |          |          |
|-----------|-----------------|------|----------|----------|
| REV.      | DESCRIPTION     | ECO  | DATE     | APPROVED |
| 1         | INITIAL RELEASE | I.R. | 04/25/13 | P.T      |

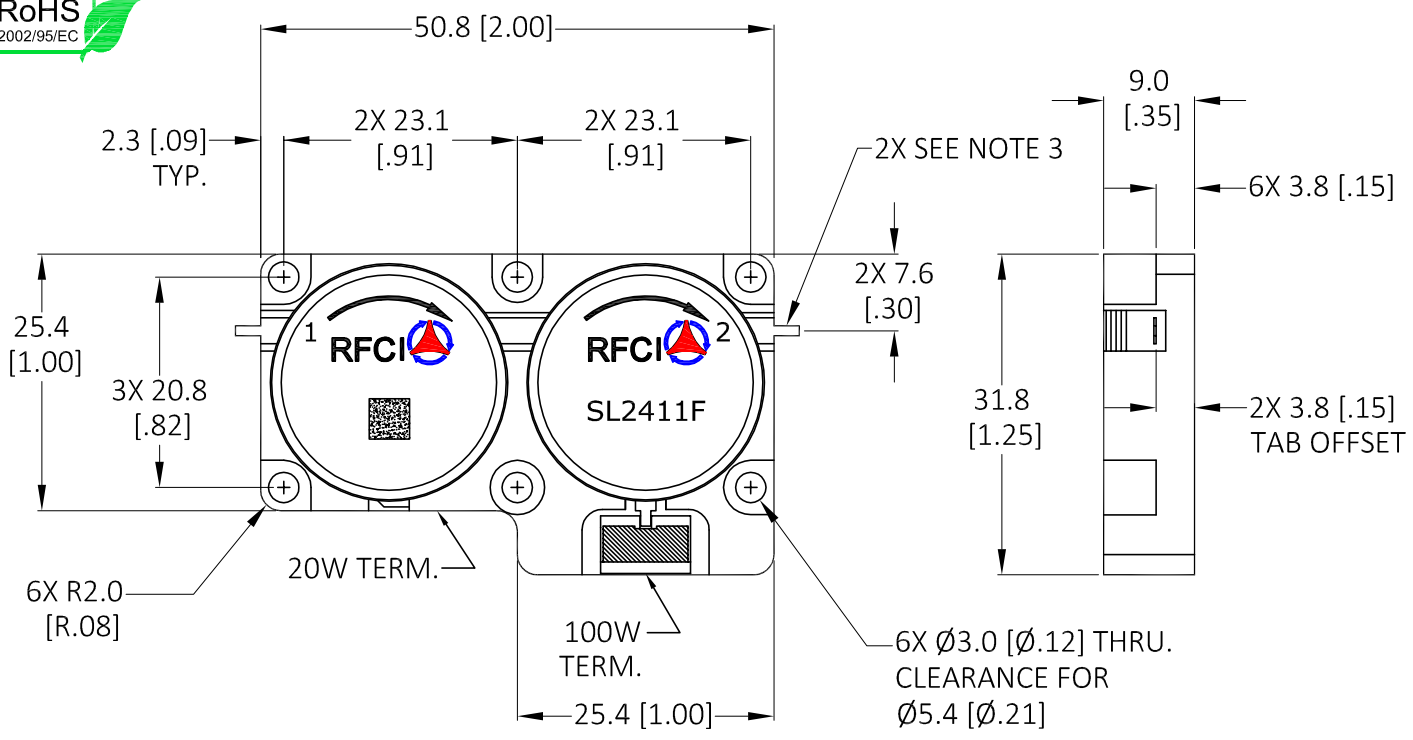

### Specifications

| Parameter             | Minimum | Typical | Maximum |
|-----------------------|---------|---------|---------|
| Frequency Range (MHz) | 1700    |         | 2100    |
| Insertion Loss (dB)   |         | < .50   | .70     |
| Isolation (dB)        | 40      | > 48    |         |
| Return Loss (dB)      | 20      | > 23    |         |

- Notes:
1. Typical Values Represent Mid-Band Performance @ +23 °C.
  2. Isolator Flange held to +85°C; 30 Min. maximum Duration.
  3. Tab Dims: 1.00[.039]Width x 2.5[.10]Length x .20[.008]Thick

### Power & Temperature Ratings

| Parameter                       | Maximum        |
|---------------------------------|----------------|
| Forward PWR Peak/AVG            | 1000/200 Watts |
| Reverse Power CW                | 100 Watts      |
| Termination Rating (See Note 2) | 100 Watts      |
| Operating Temperature           | -40 to +85° C  |
| Storage Temperature             | -40 to +95° C  |

## CW 100W DUAL ISOLATOR MODEL: SL2411F

| <p>UNLESS OTHERWISE SPECIFIED<br/>ALL DIMENSIONS ARE IN MILLIMETERS (INCHES):</p> <p>TOLERANCES ARE:<br/>1 PLACE DECIMAL ±.2 [±.01] ANGULAR: ±1.0°<br/>2 PLACE DECIMAL ±.10 [±.004] SURFACE ROUGHNESS 16/</p> <p>REMOVE ALL BURRS AND BREAK SHARP EDGES.<br/>SURFACE TEXTURE TO BE IN ACCORDANCE WITH LATEST ANSI B46.1<br/>DIMENSIONING &amp; TOLERANCING IN ACCORDANCE WITH LATEST ANSI Y14.5</p> <p>PROPRIETARY NOTE: "THE INFORMATION CONTAINED ON THIS DOCUMENT IS CONSIDERED TO BE CONFIDENTIAL MATERIAL PROPRIETARY TO RF CIRCULATOR ISOLATOR Inc. (RFCI) AND IS PROVIDED SOLELY FOR INFORMATION PURPOSES.<br/>THIS INFORMATION SHALL NOT BE USED BY ANYONE OTHER THAN RFCI TO DESIGN OR CONSTRUCT ANY OF THE ITEMS DEPICTED, NOR SHALL IT BE DISCLOSED, DUPLICATED, OR COPIED FOR ANY PURPOSE, NOR MADE AVAILABLE TO ANY THIRD PARTY WITHOUT THE PRIOR WRITTEN CONSENT OF A RFCI OFFICIAL."</p> <p>DO NOT SCALE DRAWING</p> | <p>THIRD ANGLE PROJECTION</p>                                                                                                                                                                                                                                                                                                                                                                                                                                      |                                 |           |      |              |          |                 |          |                |          |                  |          |                |         |      |  |                |
|-------------------------------------------------------------------------------------------------------------------------------------------------------------------------------------------------------------------------------------------------------------------------------------------------------------------------------------------------------------------------------------------------------------------------------------------------------------------------------------------------------------------------------------------------------------------------------------------------------------------------------------------------------------------------------------------------------------------------------------------------------------------------------------------------------------------------------------------------------------------------------------------------------------------------------------|--------------------------------------------------------------------------------------------------------------------------------------------------------------------------------------------------------------------------------------------------------------------------------------------------------------------------------------------------------------------------------------------------------------------------------------------------------------------|---------------------------------|-----------|------|--------------|----------|-----------------|----------|----------------|----------|------------------|----------|----------------|---------|------|--|----------------|
|                                                                                                                                                                                                                                                                                                                                                                                                                                                                                                                                                                                                                                                                                                                                                                                                                                                                                                                                     | <table border="1"> <thead> <tr> <th>APPROVALS</th> <th>DATE</th> </tr> </thead> <tbody> <tr> <td>DRAWN BY: HV</td> <td>04/22/13</td> </tr> <tr> <td>CHECKED BY: P.T</td> <td>04/23/13</td> </tr> <tr> <td>DESIGN BY: P.T</td> <td>04/01/13</td> </tr> <tr> <td>ENGINEER BY: P.T</td> <td>04/01/13</td> </tr> <tr> <td>MFG. ENGR. L.T</td> <td>4/24/13</td> </tr> <tr> <td>Q.A.</td> <td></td> </tr> <tr> <td>PROG. MGMT/MKT</td> <td></td> </tr> </tbody> </table> |                                 | APPROVALS | DATE | DRAWN BY: HV | 04/22/13 | CHECKED BY: P.T | 04/23/13 | DESIGN BY: P.T | 04/01/13 | ENGINEER BY: P.T | 04/01/13 | MFG. ENGR. L.T | 4/24/13 | Q.A. |  | PROG. MGMT/MKT |
| APPROVALS                                                                                                                                                                                                                                                                                                                                                                                                                                                                                                                                                                                                                                                                                                                                                                                                                                                                                                                           | DATE                                                                                                                                                                                                                                                                                                                                                                                                                                                               |                                 |           |      |              |          |                 |          |                |          |                  |          |                |         |      |  |                |
| DRAWN BY: HV                                                                                                                                                                                                                                                                                                                                                                                                                                                                                                                                                                                                                                                                                                                                                                                                                                                                                                                        | 04/22/13                                                                                                                                                                                                                                                                                                                                                                                                                                                           |                                 |           |      |              |          |                 |          |                |          |                  |          |                |         |      |  |                |
| CHECKED BY: P.T                                                                                                                                                                                                                                                                                                                                                                                                                                                                                                                                                                                                                                                                                                                                                                                                                                                                                                                     | 04/23/13                                                                                                                                                                                                                                                                                                                                                                                                                                                           |                                 |           |      |              |          |                 |          |                |          |                  |          |                |         |      |  |                |
| DESIGN BY: P.T                                                                                                                                                                                                                                                                                                                                                                                                                                                                                                                                                                                                                                                                                                                                                                                                                                                                                                                      | 04/01/13                                                                                                                                                                                                                                                                                                                                                                                                                                                           |                                 |           |      |              |          |                 |          |                |          |                  |          |                |         |      |  |                |
| ENGINEER BY: P.T                                                                                                                                                                                                                                                                                                                                                                                                                                                                                                                                                                                                                                                                                                                                                                                                                                                                                                                    | 04/01/13                                                                                                                                                                                                                                                                                                                                                                                                                                                           |                                 |           |      |              |          |                 |          |                |          |                  |          |                |         |      |  |                |
| MFG. ENGR. L.T                                                                                                                                                                                                                                                                                                                                                                                                                                                                                                                                                                                                                                                                                                                                                                                                                                                                                                                      | 4/24/13                                                                                                                                                                                                                                                                                                                                                                                                                                                            |                                 |           |      |              |          |                 |          |                |          |                  |          |                |         |      |  |                |
| Q.A.                                                                                                                                                                                                                                                                                                                                                                                                                                                                                                                                                                                                                                                                                                                                                                                                                                                                                                                                |                                                                                                                                                                                                                                                                                                                                                                                                                                                                    |                                 |           |      |              |          |                 |          |                |          |                  |          |                |         |      |  |                |
| PROG. MGMT/MKT                                                                                                                                                                                                                                                                                                                                                                                                                                                                                                                                                                                                                                                                                                                                                                                                                                                                                                                      |                                                                                                                                                                                                                                                                                                                                                                                                                                                                    |                                 |           |      |              |          |                 |          |                |          |                  |          |                |         |      |  |                |
| <p>SIZE A CAGE NO. DWG NO. SL2411F-OS REV. 1</p>                                                                                                                                                                                                                                                                                                                                                                                                                                                                                                                                                                                                                                                                                                                                                                                                                                                                                    |                                                                                                                                                                                                                                                                                                                                                                                                                                                                    | <p>SCALE: FULL SHEET 1 OF 1</p> |           |      |              |          |                 |          |                |          |                  |          |                |         |      |  |                |